

PRELIMINARY SCHEDULE P-03

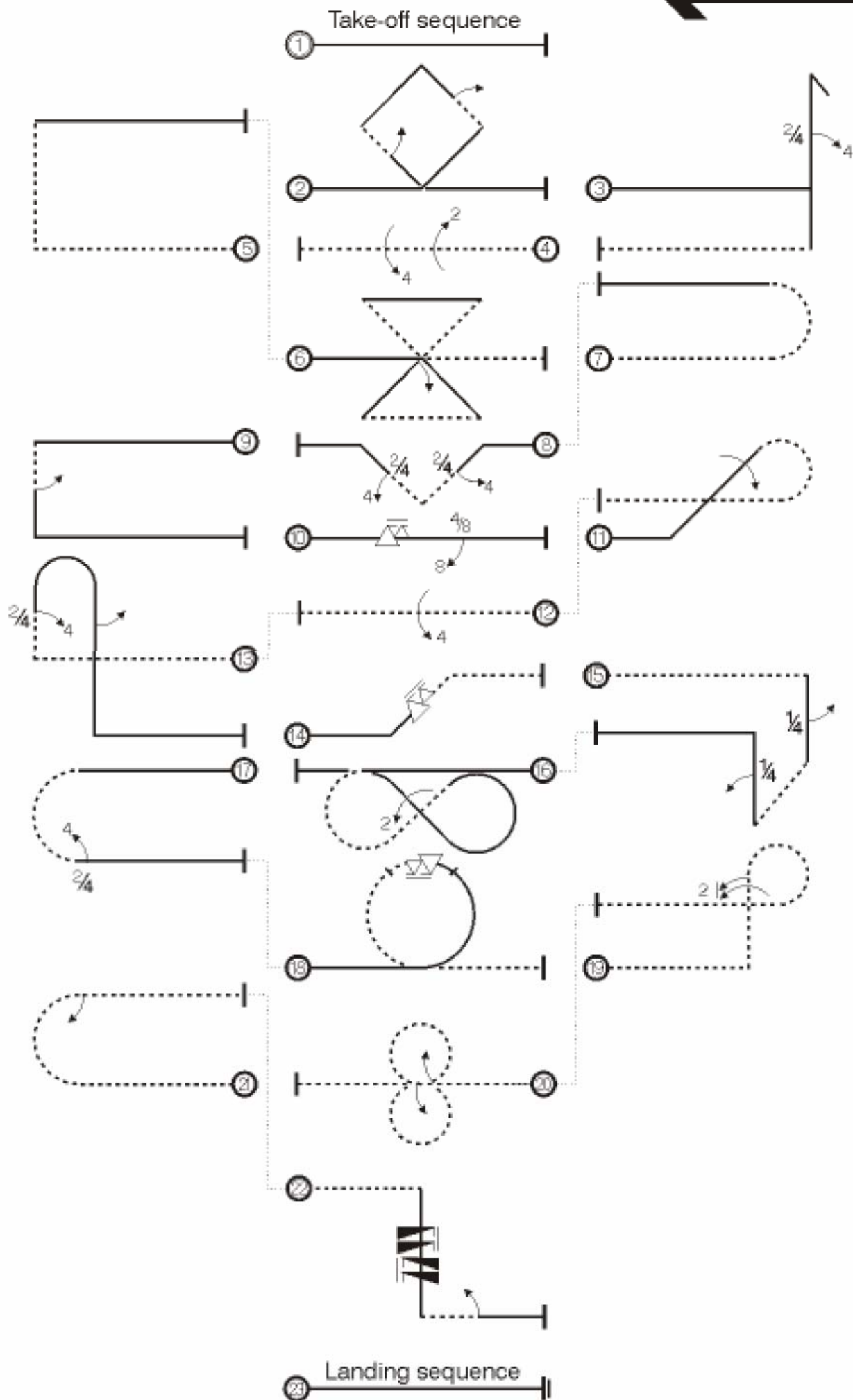

Take-off sequence



Preliminary Schedule P-03

K-Factor

1. Take-off Sequence	1
2. Square Loop on Corner, 1/2 Rolls in Legs 2 & 4.....	5
3. Stall Turn, 2/4 Pt. Roll Up, Exit Inverted.....	2
4. 2/2 Pt. Roll, 4 Pt. Roll Opposite, Exit Inverted	4
5. Half Square Outside Loop.....	1
6. Hourglass, Mid-Entry (Bottom First) 1/2 Roll Up, Exit Inverted	5
7. Half Outside Loop to Top	1
8. Cobra Roll from the Top, 2/4 Pt. Rolls	4
9. Half Square loop, 1/2 Roll Down.....	2
10. 1-1/2 Pos. Snap, 4/8 Pt. Roll	5
11. Half Reverse Cuban 8, Full Roll, Exit Inverted	2
12. 4 Pt. Roll, Inverted to Inverted.....	4
13. Push-Pull-Pull Humpty Bump, 2/4 Pt. Roll Up, 1/2 Roll Down	3
14. 45 Degrees Up, 1-1/2 Positive Snap, Exit Inverted.....	4
15. Reverse Top Hat with 1/4 Rolls	3
16. Outside/Inside Cuban 8 from the Top, 2/2 Pt. Rolls Second Up.....	4
17. Half Outside Loop, 2/4 Pt. Roll.....	2
18. Avalanche, 1-1/2 Snap Roll, Exit Inverted.....	4
19. Figure 9, 3/2 Pt. Roll Up, Exit Inverted	2
20. Rolling 8, Top First, 1/2 Rolls on Middle, Exit Inverted	3
21. Half Outside Loop to Top, 1/2 Roll, Exit Inverted.....	1
22. Two 2 Turn Inverted Spins, Opposite from Inverted, 1/2 Roll Exit.....	4
23. Landing Sequence	1